



# RED SWASTIKA SCHOOL

## 2021 SEMESTRAL ASSESSMENT 1

### MATHEMATICS PAPER 1

Name : \_\_\_\_\_ (     )

Class : Primary 6 / \_\_\_\_\_

Date : 11 May 2021

### BOOKLET A

15 Questions

20 Marks

Duration of Paper 1 (Booklets A & B): 1 hour

Note:

1. Do not open this Booklet until you are told to do so.
2. Read carefully the instructions given at the beginning of each part of the Booklet.
3. Do not waste time. If a question is difficult for you, go on to the next one.
4. Check your answers thoroughly and make sure you attempt every question.
5. In this booklet, you should have the following:
  - (a) Page 1 to Page 6
  - (b) Questions 1 to 15
6. You are not allowed to use a calculator.

Questions 1 to 10 carry 1 mark each. Questions 11 to 15 carry 2 marks each. For each question, four options are given. One of them is the correct answer. Make your choice (1, 2, 3 or 4) and shade your answer on the Optical Answer Sheet. (20 marks)

---

1 Express  $9w + 8 + 4w - 3$  in the simplest form.

- (1)  $5w + 5$
- (2)  $5w - 11$
- (3)  $13w - 5$
- (4)  $13w + 5$

2 The figure below is a parallelogram. Find  $\angle a$ .

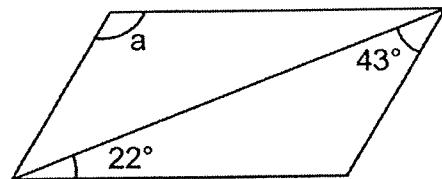

- (1)  $65^\circ$
- (2)  $115^\circ$
- (3)  $137^\circ$
- (4)  $158^\circ$

3 In the figure below, ABCD is a rhombus. Find  $\angle m$ .

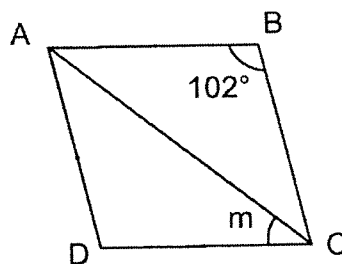

- (1)  $39^\circ$
- (2)  $44^\circ$
- (3)  $51^\circ$
- (4)  $78^\circ$

- 4 BCD is an isosceles triangle. ABD and EBC are straight lines. Find  $\angle BDC$ .

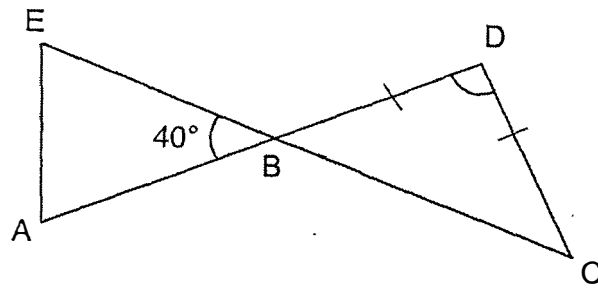

- (1)  $70^\circ$   
(2)  $80^\circ$   
(3)  $100^\circ$   
(4)  $140^\circ$
- 5 Find the value of  $4 \div \frac{5}{8}$ . Express your answer in its simplest form.

- (1)  $\frac{2}{5}$   
(2)  $\frac{5}{32}$   
(3)  $2\frac{1}{2}$   
(4)  $6\frac{2}{5}$

- 6  $\frac{3}{8}$  of David's stamps are foreign stamps and the rest are local stamps. What is the ratio of the number of local stamps to the number of foreign stamps that David has?

- (1) 3 : 5  
(2) 5 : 3  
(3) 5 : 8  
(4) 8 : 3

- 7 There are 180 boys in a Book Club. 60% of the total number of students in the club are boys. How many students are there in the club?
- (1) 120  
 (2) 270  
 (3) 300  
 (4) 450

- 8 A wire was used to form 2 identical semicircles as shown below. What was the length of wire used?  
 (Take  $\pi = \frac{22}{7}$ )

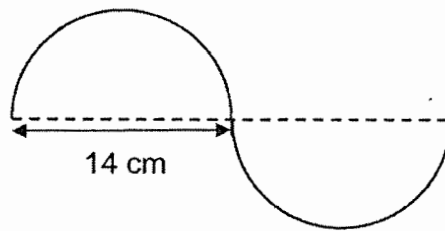

- (1) 22 cm  
 (2) 44 cm  
 (3) 58 cm  
 (4) 154 cm
- 9 In the figure below, ABCD is a square, ABE is an equilateral triangle and BFD is a straight line. Find  $\angle BFE$ .

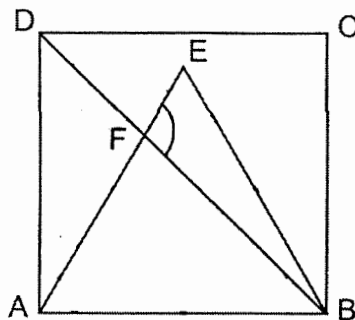

- (1)  $75^\circ$   
 (2)  $90^\circ$   
 (3)  $105^\circ$   
 (4)  $120^\circ$

- 10 The figure shows two circles. The radius of the big circle is twice the radius of the small circle. The radius of the small circle is 10 cm. Find the area of the shaded part. (Take  $\pi = 3.14$ )

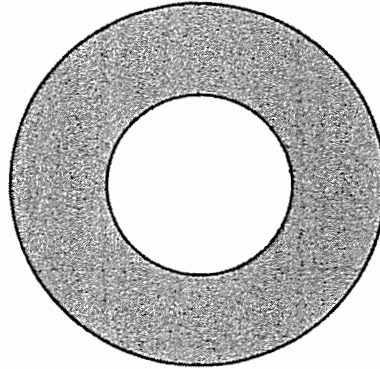

- (1)  $314 \text{ cm}^2$   
(2)  $628 \text{ cm}^2$   
(3)  $942 \text{ cm}^2$   
(4)  $1256 \text{ cm}^2$
- 11 Jenny has a box of red and blue ribbons. The ratio of red ribbons to the blue ribbons is 3 : 2. The total number of red and blue ribbons is 30. How many blue ribbons does she have?
- (1) 12  
(2) 18  
(3) 20  
(4) 45

- 12 ABC is an isosceles triangle. AC is equal to BC.  $\angle DAB = 55^\circ$  and  $\angle ACB = 40^\circ$ . Find  $\angle CAD$ .

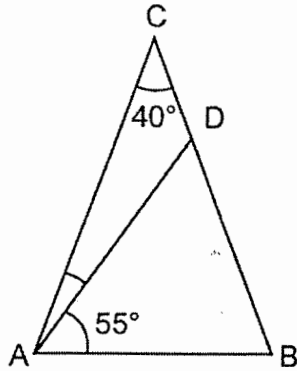

- (1)  $15^\circ$   
(2)  $30^\circ$   
(3)  $55^\circ$   
(4)  $70^\circ$
- 13 The figure below shows a cube. The area of the shaded part is  $36 \text{ cm}^2$ . What is the volume of the cube?

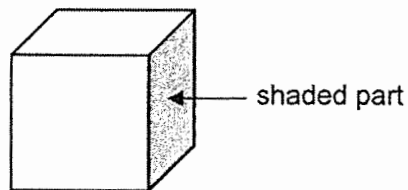

- (1)  $186 \text{ cm}^3$   
(2)  $216 \text{ cm}^3$   
(3)  $324 \text{ cm}^3$   
(4)  $729 \text{ cm}^3$

14 The length of a square is 5 cm. Find the percentage increase in the area of the square if the length of each side is increased to 10 cm.

- (1) 75%
- (2) 100%
- (3) 300%
- (4) 400%

15 Triangle XYZ is a right-angled triangle. The shaded parts, made up of a quadrant and 2 parts of a circle, have the same radius. Find the area of the shaded parts.

(Take  $\pi = 3.14$ )

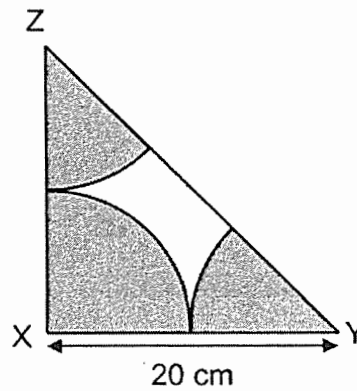

- (1) 78.5 cm<sup>2</sup>
- (2) 157 cm<sup>2</sup>
- (3) 314 cm<sup>2</sup>
- (4) 628 cm<sup>2</sup>



# RED SWASTIKA SCHOOL

## 2021 SEMESTRAL ASSESSMENT 1

### MATHEMATICS PAPER 1

Name : \_\_\_\_\_ (     )

Class : Primary 6 / \_\_\_\_\_

Date : 11 May 2021

### BOOKLET B

15 Questions  
20 Marks

In this booklet, you should have the following:

- (a) Page 7 to Page 13
- (b) Questions 16 to 30

#### MARKS

	OBTAINED	POSSIBLE
BOOKLET A		20
BOOKLET B		25
TOTAL		45

Parent's Signature : \_\_\_\_\_



Questions 16 to 20 carry 1 mark each. Write your answers in the spaces provided. For questions which require units, give your answers in the units stated. (5 marks)

---

16 Express 18 m 2 cm in metres.

Ans: \_\_\_\_\_ m

---

17 Divide 306 000 by 900.

Ans: \_\_\_\_\_

---

18 A movie started at 10.45 a.m. and ended at 1.05 p.m. How long was the movie in hours and minutes?

Ans: \_\_\_\_\_ hours \_\_\_\_\_ minutes

---

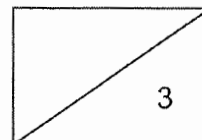

- 19 The graph below shows the number of washing machines sold by a shop from April to June.

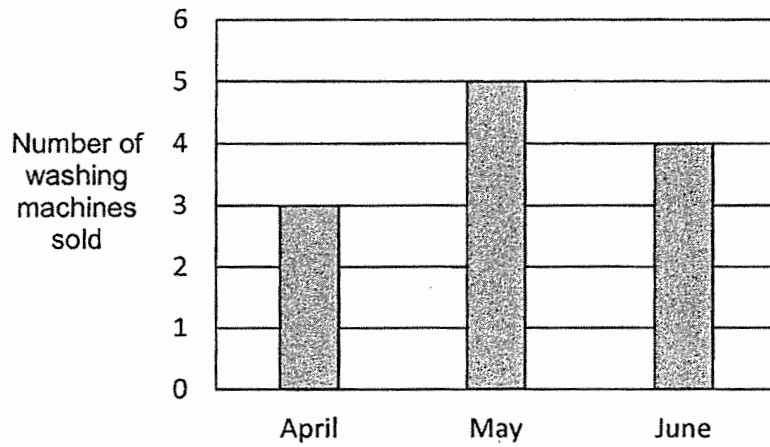

Find the average number of washing machines sold by the shop from April to June.

Ans: \_\_\_\_\_

- 20 The figure is made up of three identical squares ABGH, BCFG and CDEF. What fraction of the figure ADEH is shaded?

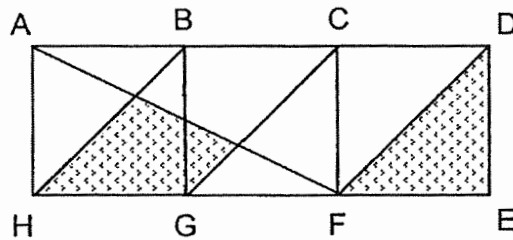

Ans: \_\_\_\_\_

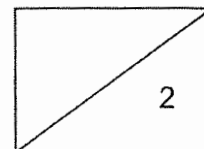

Questions 21 to 30 carry 2 marks each. Show your working clearly and write your answers in the spaces provided. For questions which require units, give your answers in the units stated. (20 marks)

---

- 21 Mdm Siti poured  $\frac{4}{9}$  l of water from a jug equally into 2 cups. Find the amount of water in each cup. Give your answer in the simplest form.

Ans: \_\_\_\_\_ l

---

- 22 Sean bought  $\frac{7}{8}$  kg of peanuts. He repacked the peanuts into some bags, each containing  $\frac{1}{16}$  kg of peanuts. How many bags of peanuts did Sean pack?

Ans: \_\_\_\_\_

---

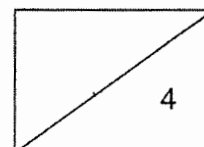

- 23 Mrs Menon spent 30% of her salary and had \$2100 left. How much did she spend?

Ans: \$ \_\_\_\_\_

---

- 24 The figure below is made up of a quadrant and a triangle.  
Find the area of the figure. (Take  $\pi = \frac{22}{7}$ )

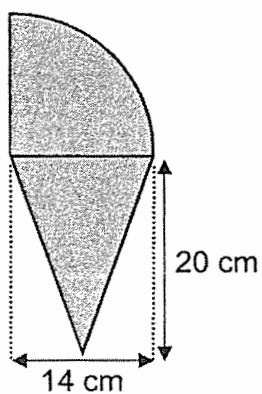

Ans: \_\_\_\_\_ cm<sup>2</sup>

---

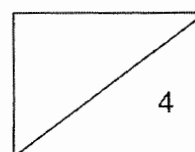

- 25 The total age of Sally and her brother was 15p years old 4 years ago. Sally is 6p years old now. Express her brother's current age in terms of p.

Ans: \_\_\_\_\_

- 26 In the figure below, DEFG is a rhombus. Find  $\angle DHF$ .

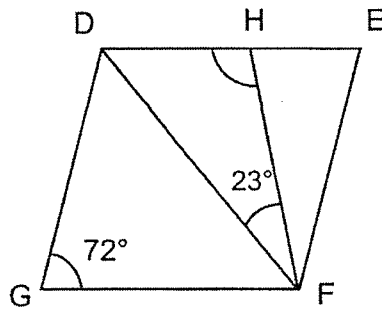

Ans: \_\_\_\_\_°

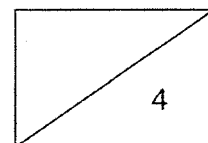

- 27 In the figure below, ABCD is a parallelogram. Find  $\angle DEC$ .

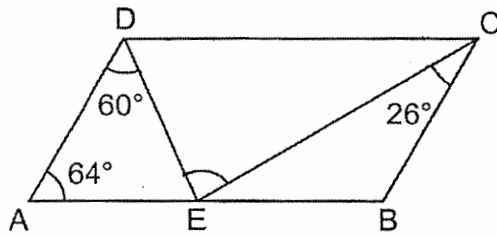

Ans: \_\_\_\_\_ $^\circ$

- 28 Hakim has a folded piece of paper as shown in Figure 1. He unfolded it to be a rectangular piece of paper as shown in Figure 2. Find  $\angle m$ .

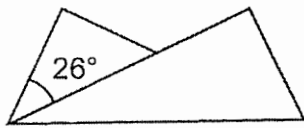

Figure 1

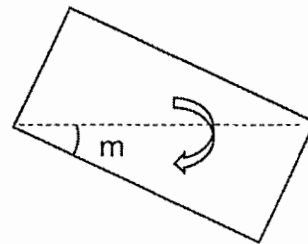
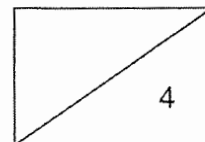

Figure 2

Ans: \_\_\_\_\_ $^\circ$



- 29 Nurul and Priya shared the total cost of a present. Nurul paid \$9 more than  $\frac{2}{5}$  of the cost of the present. Priya paid \$27. How much did the present cost?

Ans: \$ \_\_\_\_\_

---

- 30 The figure below is made up of a triangle and a circle. The ratio of the area of the triangle to the area of the circle is 5 : 6. If  $\frac{1}{5}$  of the area of the triangle is shaded, what is the ratio of the shaded area to the area of the figure?

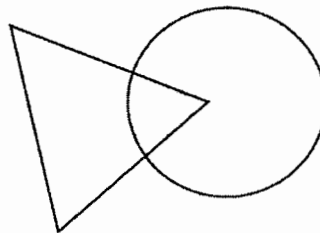

Ans: \_\_\_\_\_

---

END OF PAPER 1

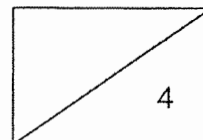



**RED SWASTIKA SCHOOL**  
**2021 SEMESTRAL ASSESSMENT 1**  
**MATHEMATICS**  
**PAPER 2**

Name : \_\_\_\_\_ (      )

Class : Primary 6 / \_\_\_\_\_

Date : 11 May 2021

17 Questions

55 Marks

Duration of Paper 2: 1 hour 30 minutes

**Note:**

1. Do not open this Booklet until you are told to do so.
2. Read carefully the instructions given at the beginning of each part of the Booklet.
3. Do not waste time. If a question is difficult for you, go on to the next one.
4. Check your answers thoroughly and make sure you attempt every question.
5. In this paper, you should have the following:
  - (a) Page 1 to Page 15
  - (b) Questions 1 to 17
6. You are allowed to use a calculator.

**MARKS**

	OBTAINED	POSSIBLE
PAPER 1		45
PAPER 2		55
TOTAL		100

Parent's Signature : \_\_\_\_\_



Questions 1 to 5 carry 2 marks each. Show your working clearly and write your answers in the spaces provided. For questions which require units, give your answers in the units stated. (10 marks)

---

- 1 The ratio of the number of cards Li Wei had to the number of cards Shafiq had was 3 : 7. After Shafiq gave 6 cards to Li Wei, both of them had the same number of cards. How many cards did Shafiq have at first?

Ans: \_\_\_\_\_

---

- 2 The shaded figure below is made up of four identical quadrants. Find the perimeter of the shaded figure. (Take  $\pi = \frac{22}{7}$ )

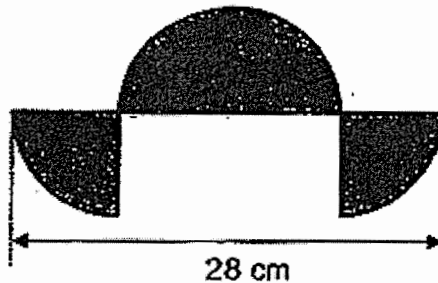

Ans: \_\_\_\_\_ cm

---

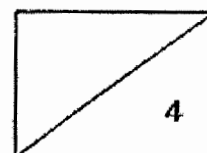

- 3 40 people signed up for a baking class last year. This year, there was a 20% increase in the number of people who signed up. How many people signed up this year?

Ans: \_\_\_\_\_

---

- 4 Jane cuts a rope into 3 pieces. The average length of the 3 pieces of rope is 18 cm. The lengths of the three pieces of rope are as shown. Find the value of  $u$ .



$(2u)$  cm

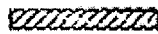

$(u)$  cm

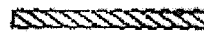

$(u + 6)$  cm

Ans: \_\_\_\_\_

---

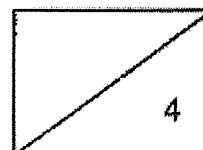

5 In the square grid below, CD and DE are straight lines.

- (a) CD and DE are two sides of a parallelogram CDEF. Complete the drawing of the parallelogram and label F. [1]
- (b) DE is also a side of triangle DEG. Area of triangle DEG is 8 square units. Complete the drawing of the triangle such that it does not overlap with parallelogram CDEF. Label G. [1]

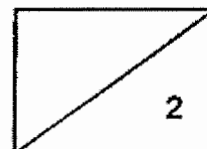
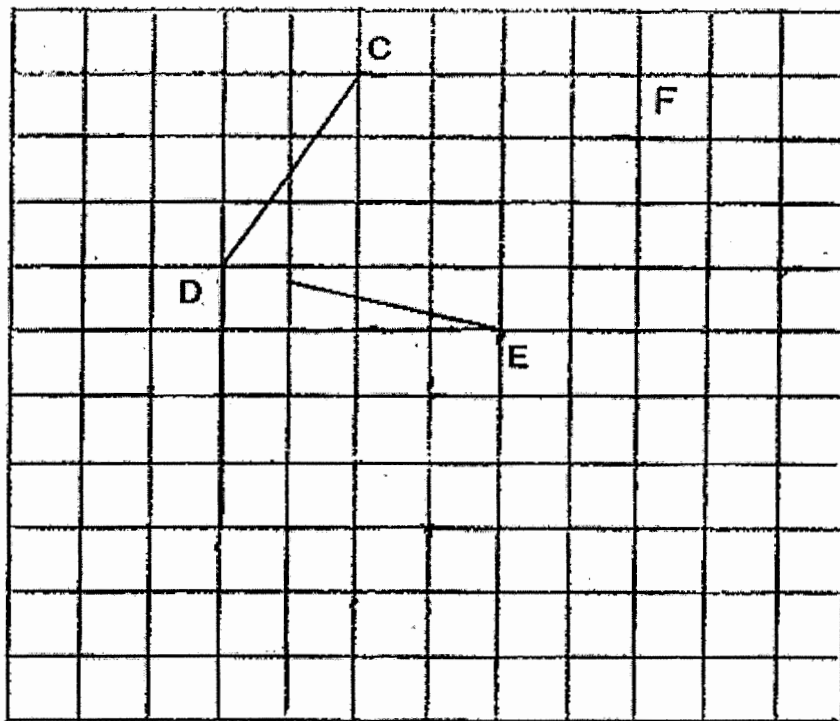

For Questions 6 to 17, show your working clearly and write your answers in the spaces provided. The number of marks available is shown in brackets [ ] at the end of each question or part-question. (45 marks)

- 6 In the figure below, PQR and PTS are straight lines and  $QT = TS$ .  
 (a) Find  $\angle QSR$ .

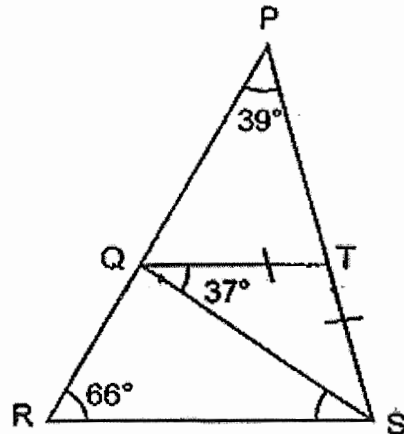

Ans: (a) \_\_\_\_\_ [2]

- (b) Circle the words that describe QRST correctly in the following statement:

QRST ( is / is not ) a trapezium because QT ( is / is not ) parallel to RS.

[1]

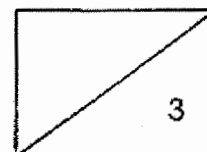

- 7 The figure below is formed by two identical semicircles and a quadrant. What is the area of the shaded part? ( Take  $\pi = 3.14$  )

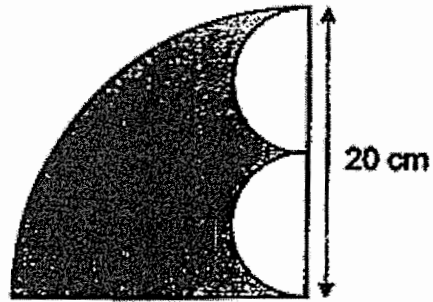

Ans: \_\_\_\_\_ [3]

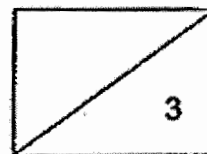

- 8 Figure X is a rectangle and Figure Y is a square. Both have the same area. Figure X is divided into 3 parts, A, B, and C.

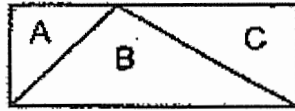

Figure X

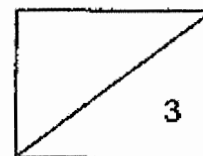

Figure Y

Each statement below is either true, false or not possible to tell from the given information.

For each statement, put a tick (✓) in the correct column.

Statement	True	False	Not possible to tell
Ratio of area of A to area of B to area of C is 1 : 3 : 2.			
Ratio of area of B to area of X is 1 : 3.			
If the ratio of area of A to area of B is 1 : 5, then the ratio of area of C to area of Y is 2 : 5.			



- 9 A quadrant was cut away from a rectangular cardboard as shown below. The radius of the quadrant is 7 cm. The perimeter of the remaining cardboard is 125 cm. The breadth of the cardboard is 21 cm. Find the length of the cardboard. ( Take  $\pi = \frac{22}{7}$  )

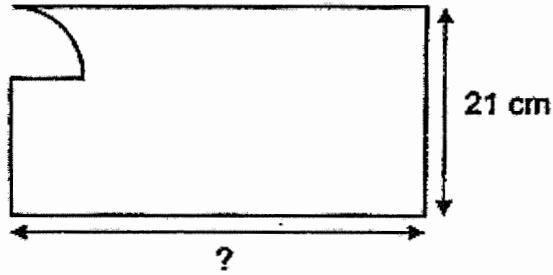

Ans: \_\_\_\_\_ [3]

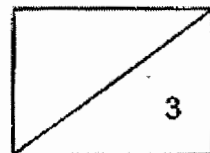

- 10 The figure below is made up of 2 identical squares, 2 identical semicircles and 1 rectangle. The length of the square is 16 cm. What is the area of the figure? (Take  $\pi = 3.14$ )

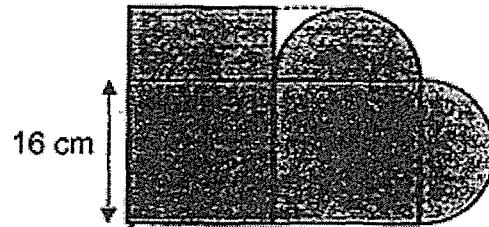

Ans: \_\_\_\_\_ [5]

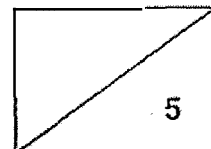



- 11 In March, Jenny withdrew \$2000 from the bank. She spent 10% of it on transport, 60% of it on shopping and the rest on food. In April, she withdrew less from the bank. She spent the same amount of money on transport but reduced her spending on shopping by 10%. She spent the remaining 20% on food.
- (a) How much did she spend on food in March?
- (b) How much did she withdraw from the bank in April?

Ans: (a) \_\_\_\_\_ [1]

(b) \_\_\_\_\_ [2]

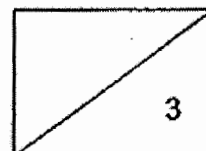

- 12 John had 60 cubes of side 2 cm. He packed all the 60 cubes tightly into a rectangular box. The box is filled to its brim exactly.

The figure below, not drawn to scale, shows the first layer of cubes packed in the box.

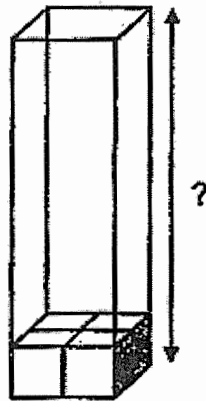

- (a) What is the height of the box?

He wanted to pack the cubes into another box as shown below.

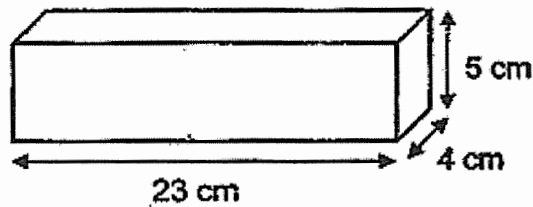

- (b) How many cubes can he put into this box at most?

Ans: (a) \_\_\_\_\_ [1]

(b) \_\_\_\_\_ [2]

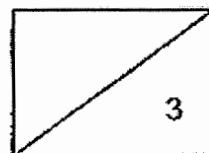

- 13 The figure below shows a quadrant AOB. OA, OB and OC are radii of the quadrant. AB and BC are straight lines.

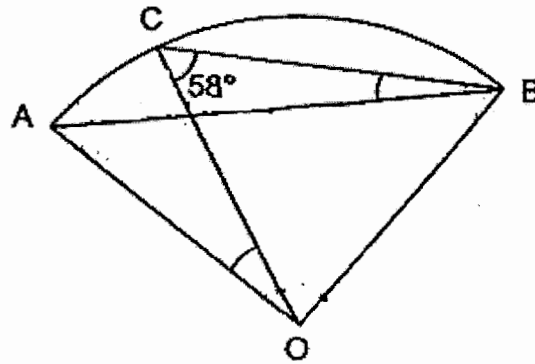

- (a) Name an isosceles triangle in the given figure.  
 (b) Find  $\angle ABC$ .  
 (c) Find  $\angle AOC$ .

Ans: (a) \_\_\_\_\_ [1]  
 (b) \_\_\_\_\_ [2]  
 (c) \_\_\_\_\_ [2]

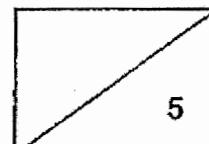

- 14 Mdm Jaya made some cookies to sell.  $\frac{3}{4}$  of them were chocolate cookies and the rest were butter cookies. After selling  $\frac{5}{6}$  of the chocolate cookies and 105 butter cookies, she had  $\frac{1}{5}$  of the cookies left. How many cookies did she make?

Ans: \_\_\_\_\_ [4]

---

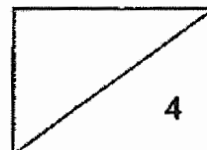

- 15 There were 2 fitness classes, A and B, in Superfit Gym. In Class A, the ratio of men to women was 4 : 3. In Class B, the ratio of men to women was 3 : 1.

$\frac{1}{3}$  of the men in Class A left to join Class B. As a result, the number of men in Class B increased to 46. The ratio of men to women in Class B became 23 : 5.

- (a) How many men left Class A to join Class B?  
(b) How many women were there in Class A?

Ans: (a) \_\_\_\_\_ [2]

(b) \_\_\_\_\_ [2]

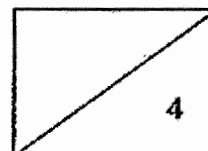

16 Fresh Bakery sells curry buns at 80 cents each and kaya buns at 50 cents each. Ben bought some curry buns and Jerry bought some kaya buns. Ben spent 90 cents more than Jerry but had 6 buns fewer than Jerry.

- (a) How many curry buns did Ben buy?
- (b) How much did Jerry spend on the kaya buns?

Ans: (a) \_\_\_\_\_ [3]

(b) \_\_\_\_\_ [2]

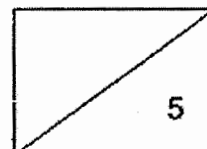

- 17 The figure below is made up of nine 1-cm squares.

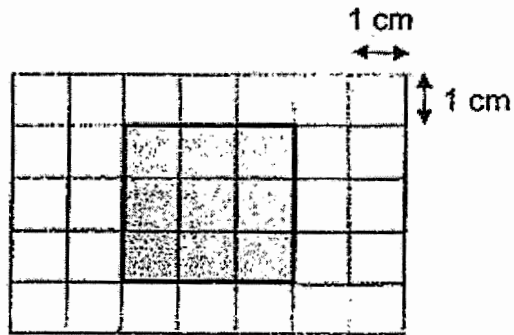

- (a) What is the perimeter of the figure?
- (b) On the square grid below, draw a rectangle with the same perimeter as the figure but with the smallest possible area. The length and breadth are whole numbers.  
[1]

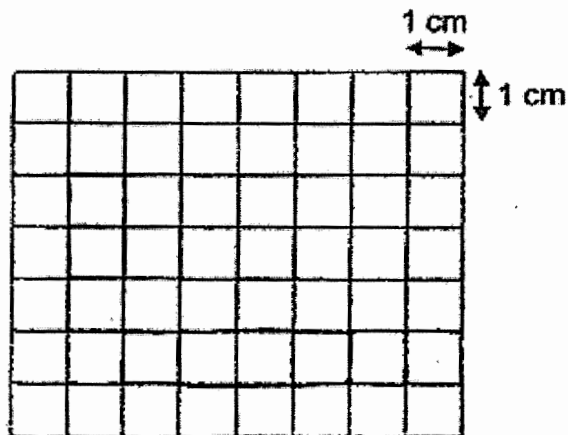

- (c) The perimeter of a rectangle is 30 cm. What is the greatest possible area of the rectangle given that the length and breadth of the rectangle must be whole numbers?

Ans: (a) \_\_\_\_\_ [1]

(c) \_\_\_\_\_ [2]

END OF PAPER 2

